

Technical sheet 20MT 3x1 TC

« All-road » self-propelled mini-crane with accompanying operator

2 pages

Innovation 2014

The 20MT 3x1 TC crane with variable wheelbase replaces the 20MB model. It is more powerful, more open ended and more accurate.

Its patent kinematic with three cylinders, manufactured by Mobilev Cranes allows to spread the jib with a biggest angle and with the possibility at the same time to lift the load in a vertical axe ("simultaneous control of the three cylinders", stroke 200 mm in option).

The « 18° slewing ring » option without stabilizers is now available for this new model. The hook's lateral adjustment could also operate without moving the mini-crane.

Finally, with the "hydraulic variable speed drive" option, all the speeds are now adjustable from 0 to 100% with the wired remote control or radio remote control (option).



Technical specifications



Maxi load	2160 kg
Unladen weight	1550 kg
Admissible slope	10 %
Maxi translation speed	5 km/h
Adjustable lifting speed	from 0 to 15 cm/s
Adjustable telescoping speed ..	from 0 to 13 cm/s
Batteries	24V - 240 Ah
Hydraulic power station engine	2.2 kW
Translation power engine	1.5 kW

Standard equipment

Hydraulic variable wheelbase
SRT ⁽¹⁾ wheels
 2 speeds hydraulic power
 Electrical drive wheel controlled by variable speed drive
 Tiller arm with butterfly acceleration & emergency Reverse
 Automatic braking system
 Automatic parking brake
 Anti-tilt system
 Wired remote control 3 or 5 axes with emergency stop
 Box for equipment
 Interchangeable traction batteries

Main options

Additional jib 500 kg
 Additional jib with manual telescope 500/350 kg
 Additional jib with manual telescope 350/250 kg
 Electric winch 500 Kg
 18° hydraulic slewing ring
 Simultaneous control of the three lifting cylinders
 Hydraulic variable speed drive
 Radio remote control

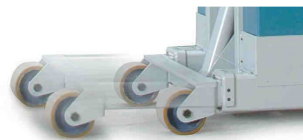

Variable wheelbase

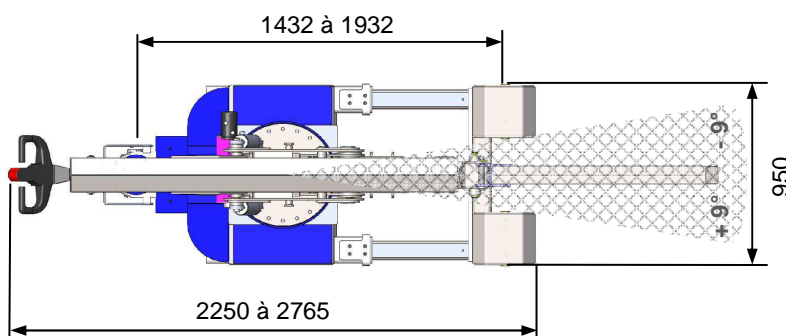

⁽¹⁾ **SRT** : Solid Resilient Tires

Technical sheet 20MT 3x1 TC

« All-road » self-propelled mini-crane with accompanying operator



Anti-slack area



Wired remote control 3 or 5 axes with emergency stop

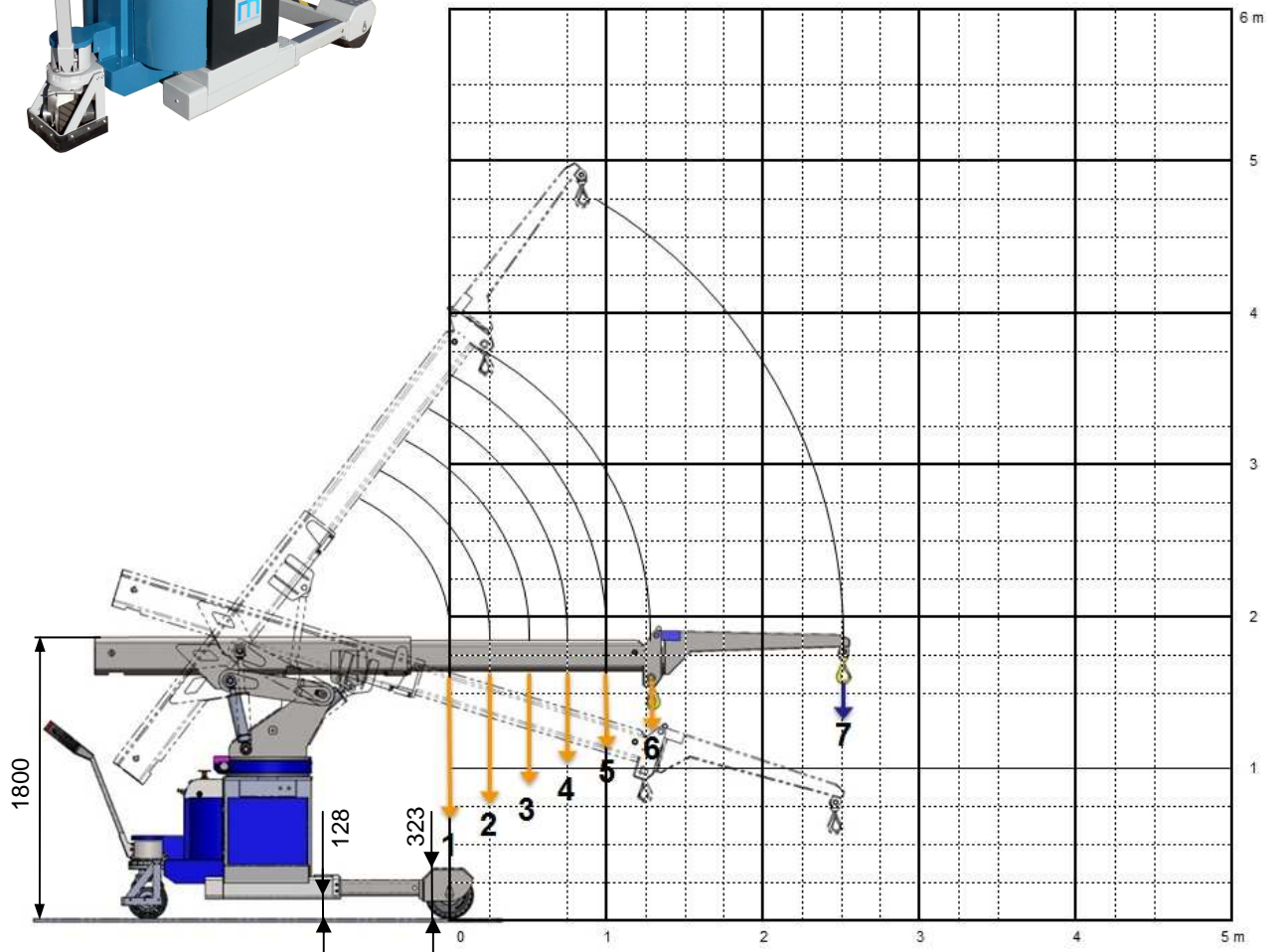

	1	2	3	4	5	6	7
Variable wheelbase out (kg)	2160	1400	1200	1080	960	890	480
Variable wheelbase in (kg)	2160	1050	740	590	490	430	210